

Tasks T1 – T10 carry 3 points each

T1. Infinite Ice-Cream

There are two ice-cream stands. They use the same four flavours:



The first stand uses the following instructions to make ice-cream:

0. Start with an empty cone.
1. Pick a flavour at random, and add two scoops of that flavour.
2. Add one scoop of any different flavour.
3. If the requested height is reached, stop, otherwise go to Step 1.

The second stand does not follow any instructions.

Question/Challenge:

You can only see the first few scoops of each ice-cream cone. Which one is certainly from the second stand?

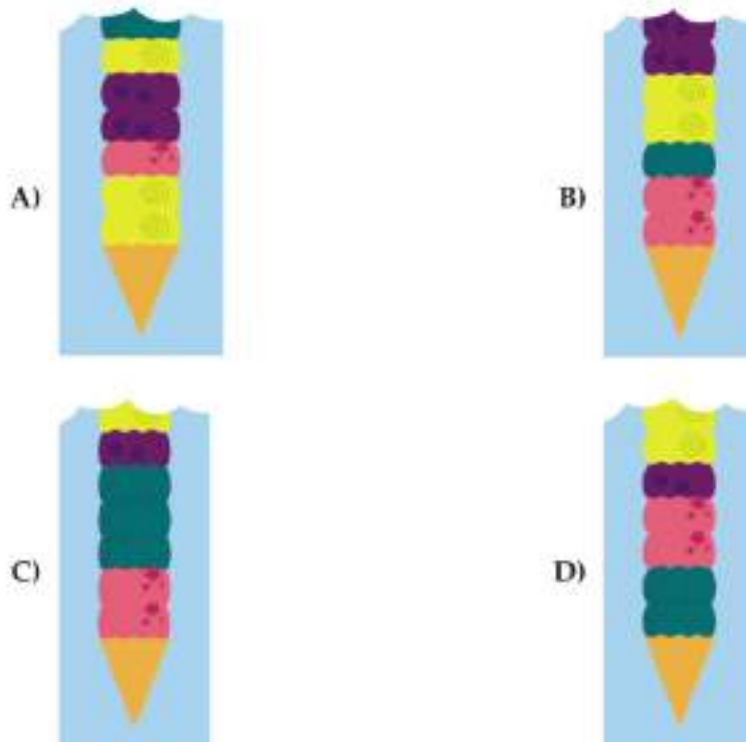

T2. Mutation of an Alien

An alien has a head, a body, two arms, and two legs. An alien can be transformed through the following mutation commands. It is possible that the shape of a part is mutated more than once.

Mutation Commands

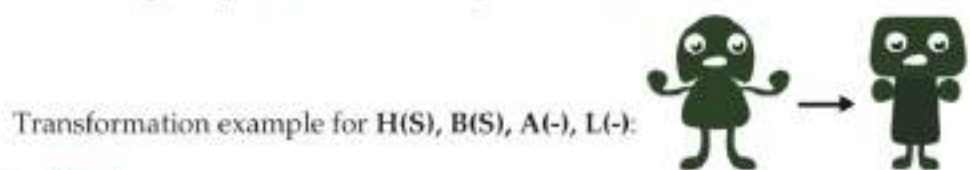

Question/Challenge:

According to the following mutation commands in sequence, what will the alien look like?

H(T), L(+), B(T), A(+), H(C), A(-), B(C)

- A) 
- B) 
- C) 
- D) 

T3. Books in a box

Anna has a new bookshelf she would like to put her books on. She'll use an empty box to store the books until the shelf is ready. She puts books in the box one at a time, lying them flat on top of each other. (The last book added is going to be seen from the top.)

Anna takes the first book from the top of the box, then one by one she stands them up (places them vertically) on the bookshelf, until the box is empty.



Question/Challenge:

Anna placed the books into the box in this order: G, N, I, O, D, C.
What is the correct order of the books on the bookshelf?

- A) G, N, I, O, D, C
C) C, D, O, I, N, G

- B) C, O, D, I, N, G
D) C, O, D, I, G, N

T4. Trees in a Circle

Joni Beaver is mapping out trees that she wants to use for her dam. She must put some wrapping around the trees, and all trees that are inside the wrapping will be available to her. For example if the trees, when viewed from above, are arranged as follows, then Joni can wrap them in the following way:

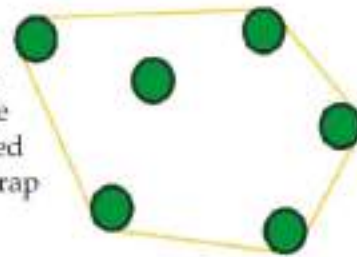

There are 6 trees in total inside the wrapping, but only 5 trees are touched by the wrapping.

Question/Challenge:

If the trees, when viewed from above, are arranged as follows:



how many trees are touched by the wrapping?

- A) 4 B) 5 C) 6 D) 7

T5. Medal Ranking

In the table below the medal rankings of the Olympic Games of 2016 are shown. The columns Gold, Silver and Bronze show the amount of gold, silver or bronze medals that a country has won.

Rank	Country	Gold	Silver	Bronze
1	United States	46	37	38
2	Great Britain	27	23	17
3	China	26	18	26
4	Russia	19	18	19
5	Germany	17	10	15
6	Japan	12	8	21
7	France	10	18	14
8	South Korea	9	3	9
9	Italy	8	12	8
10	Australia	8	11	10
11	the Netherlands	8	7	4
12	Hungary	8	3	4

Question/Challenge:

Suppose the Netherlands had won one gold medal more. What is the final position of the Netherlands in the table ranking?

- A) 5 B) 9 C) 7 D) 8

T6. Planet B

People on Planet B develop cities in a special way. They start with one house. Then they make replacements using these three rules:

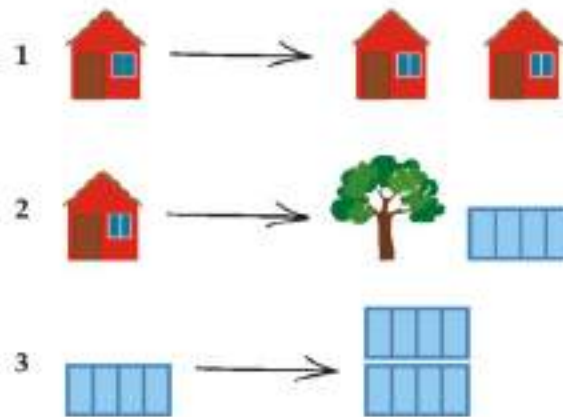

For example, if we apply rule 1, then rule 2, and then rule 3 twice, we get:



Observe that none of the objects switch places.

Question/Challenge:

Which of these cities is **NOT** on Planet B?

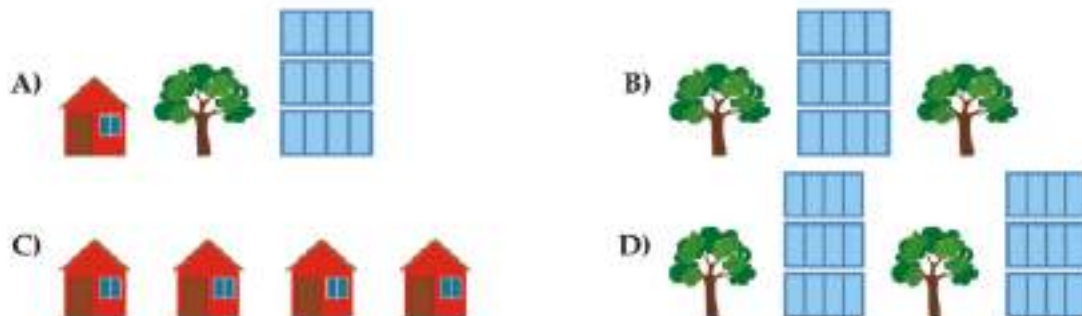

T7. Lemonade Party

Janet made 37 liters of lemonade at home and now she wants to take it for a celebration at the school. She has several empty bottles with various sizes but she wants to use the smallest number of them to bottle exactly 37 liters of lemonade.

She can use the following bottles from the table:

1 liter				
2 liter				
4 liter				
8 liter				
16 liter				
32 liter				

Question/Challenge:

What is the smallest number of bottles to fill exactly 37 liters of lemonade?

- A) 5 B) 3 C) 2 D) 6

T8. Clara likes Flowers

Clara likes colorful bouquets of flowers and visits a flower shop. In there are the following types of flowers:



gladiolus



lily



tulip



rose

Every flower is available in the colors:

white

blue

yellow

Clara wants a bouquet with six flowers satisfying the following conditions:

- 1) each of the colors yellow, white and blue should occur exactly twice,
- 2) flowers of the same type should not have the same color,
- 3) every type of flower should only occur at most twice.



Question/Challenge:

Which of the following bouquets satisfies all the conditions 1), 2) and 3)?



T9. Beaver nesting doll

A beaver nesting doll is a set of wooden dolls that all fit inside each other. Each doll can be opened from the middle to show another doll with smaller width and smaller height inside.

Emily has been told that her Beaver nesting dolls are magic. If she makes a wish, the more layers of dolls, the faster her wish comes true.

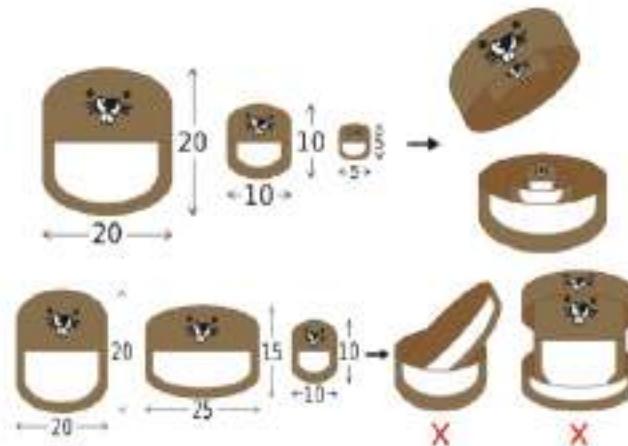

The following shows all the beaver nesting dolls Emily has. She wants to combine as many dolls as she can.

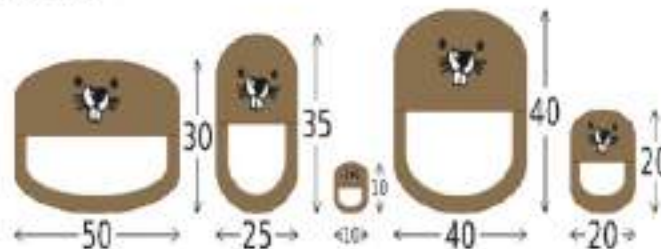

Question/Challenge:

How many layers of beaver nesting dolls can Emily get?

- A) 4 B) 5 C) 6 D) 2

T10. Beaver tables

A beaver has a small table for 6 chairs



However the small table is too small for a big family. So he decided to build a bigger table by joining small tables in the following way:

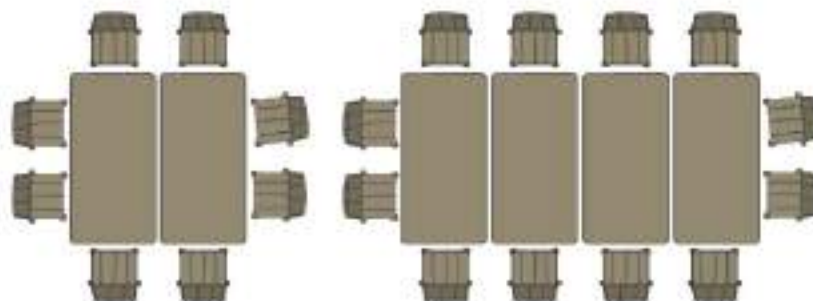

Question/Challenge:

If the beaver wants to put 35 chairs around the bigger table, how many of the small tables would he need?

A) 15

B) 8

C) 16

D) 4

Tasks T11 – T20 carry 4 points each

T11. Simon Says

We play a simple push square game. The starting position is shown below.



The game involves following a sequence of rotation instructions. After the rotation we push the top-left square. For example, 2R (twice clockwise) would look like:



The next rotation instruction would be to push the yellow square.

Question/Challenge:

From the starting position, what colours are pushed after we perform the following rotation instruction: 1R 2R 2R 3R ?

A) Green Blue Green Yellow

B) Blue Yellow Red Green

C) Red Yellow Red Blue

D) Blue Green Blue Red

T12. Beaver Village Words I

In a beaver village there started to appear strange graffiti. Local authorities investigated the situation and found out that they consists of three different symbols:



Furthermore, they are composed using only two simple rules:

- First, a symbol is chosen and it is drawn once or twice.
- The next rule is repeated an arbitrary many times (even never): a symbol is chosen and it is drawn once to left and to the right of all so far drawn symbols.

Here are five examples of graffiti:

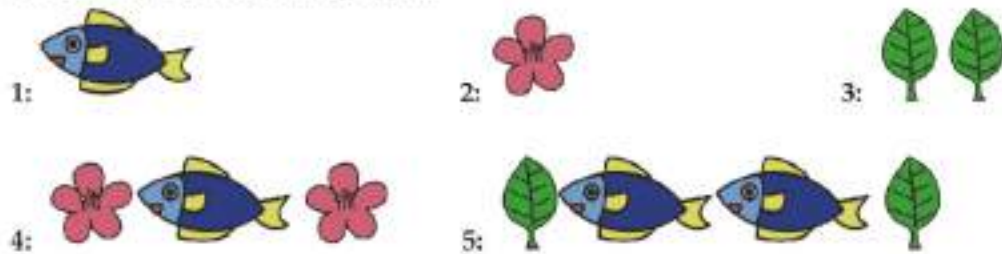

Question/Challenge:

Which of the following graffiti is not from the beaver village?

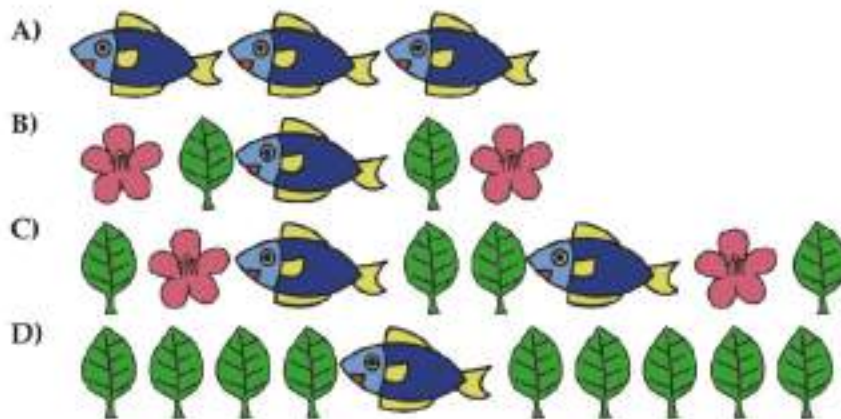

T13. A lie has no legs

On a beautiful day, Maja, David, Iva, and Marko played football near their teacher Ana's house. Unfortunately, one of them broke her window. Teacher Ana wanted to know who broke the window. Ana knows her students well. Three of them always tell the truth, but she does not know about the fourth one.

The children said:

Marko: I haven't broken the window

Iva: Marko or David broke the window

Maja: David broke the window

David: No, Maja you lie!

Question/Challenge:

Who broke the window?

- A) Maja
- C) Iva





































- B) David
- D) Marko

T14. Twists and turns

Tom is a 10 year boy living in Sarbeč, a city with a lot of twists and turns. His mom forgot her phone at home and asked Tom to bring it to her work. In order not to get lost, she sends Tom a street map. The map is drawn as a table, with columns numbered from 1 to 6 and rows from A to F. The map contains also a legend:

-  - Tom can only go down
-  - Tom can go either left or down
-  - Tom hits an obstacle that he can't continue beyond
-  - Tom can go either down or right
-  - Tom can go either up or left

Tom is starting from the first row of the first column (point A1) and his mom is located on the last row of the last column (point F6).

	1	2	3	4	5	6
A						
B						
C						
D						
E						
F						

Question / Challenge

Which of the following routes is the correct route that could be used by Tom?

- A) A1 B1 B2 B3 C3 D3 E3 E4 F4 F5 F6
- B) A1 B1 B2 B3 B4 C4 D4 D5 D6 E6 F6
- C) A1 B1 B2 B3 C3 D3 E3 F3 F4 F5 F6
- D) A1 B1 B2 B3 C3 D3 D4 D5 D6 E6 F6

T15. Finding The Route

Beaver Zac walked a route of 8 kilometers following straight lines of 1 kilometer length. After every 1 kilometer, Zac should turn either left or right. At each turn he wrote in a notebook the symbol 1 or 0. But we don't know which symbols corresponds to the left and rights turns. The entire route is coded as 1000100.

Question/Challenge:

Which of the following maps shows the possible correct routes? In each case, Zac's starting point and direction are shown in the figure below.

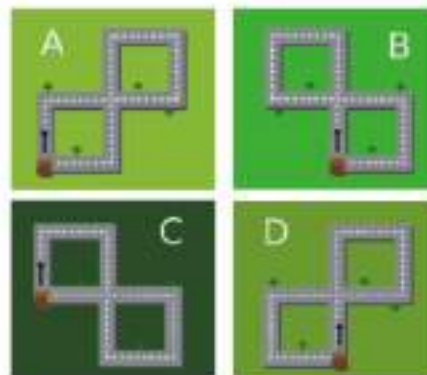

- A) Only B
- B) A, B and D
- C) A, D
- D) B, D

T16. Camping Beaver

Beaver Judy loves to go camping with her family. She takes a different set of items for camping, depending on where she is planning to go.

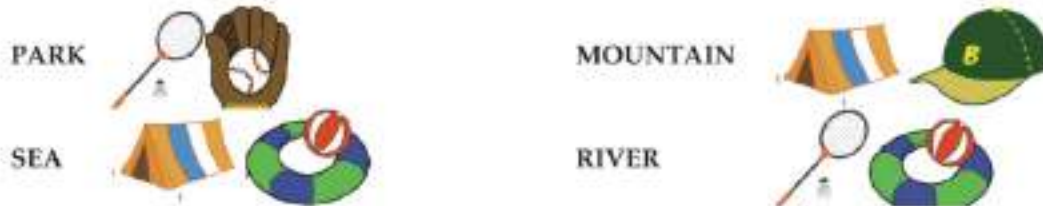

Judy's camping items are stored in a warehouse. After each trip, the freshly used camping items are placed on the left of the unused ones. Here are photos of the warehouse before and after a trip to the park.



Question/Challenge:

Judy's family went to two camping trips recently. Here are photos of Judy's warehouse before and after the two trips. Which two places did they go camping in?

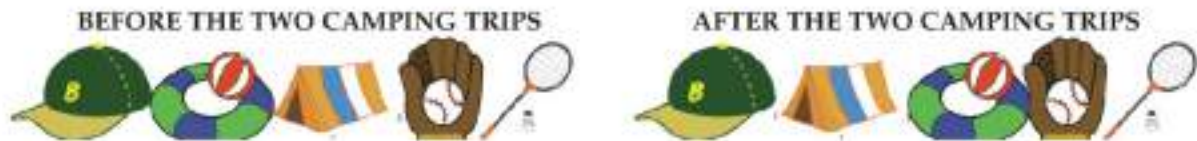

- A) Park, Sea
- B) Park, River
- C) Sea, Mountain
- D) Park, Mountain

T17. Dam Construction

Engineer Beaver wants to build a dam to protect her house from the winter flood. She has at her disposal a number of log piles as shown in Figure 1, from which she wants to produce the dam shown in Figure 2. Further, it takes her 1 hour to move a pile of logs in vertical direction on the figure, and 2 hours in horizontal direction.

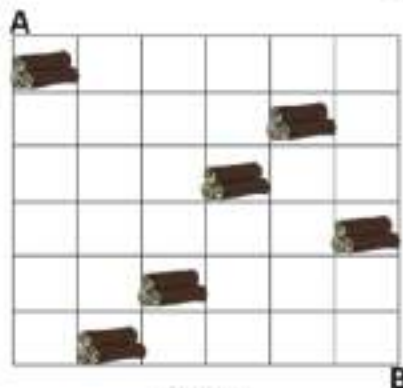

Figure 1

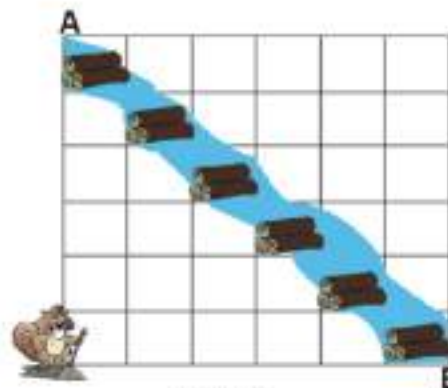

Figure 2

Question/Challenge:

What is the minimum number of hours it will take the Engineer Beaver to build the dam?

- A) 16 B) 11 C) 14 D) 12

T18. Drawing Game

Beaver Joe plays a drawing game that uses logs to draw shapes. There are four commands that he can use:

- **PUT_FLAG** – to mark the starting point and **start painting**
- **LOG_UP** – to draw a log pointing **upward**
- **LOG_RIGHT** – to draw a log lying horizontally to the **right**
- **GOTO_FLAG** – to **go to flag** and continue drawing from the flag

For example, to draw a vertical log, Joe types the command:

PUT_FLAG, LOG_UP:



To draw the following form, Joe types:

PUT_FLAG, LOG_UP, LOG_RIGHT:



Question/Challenge:

What is the sequence of commands that Joe should type to draw a square?

- A) PUT_FLAG, LOG_UP, LOG_RIGHT, LOG_RIGHT, LOG_RIGHT
 B) PUT_FLAG, LOG_UP, LOG_RIGHT, LOG_UP, LOG_RIGHT
 C) PUT_FLAG, LOG_UP, LOG_RIGHT, GOTO_FLAG, LOG_UP, LOG_RIGHT
 D) PUT_FLAG, LOG_UP, LOG_RIGHT, GOTO_FLAG, LOG_RIGHT, LOG_UP

T19. Colourful Bricks

The table below shows all instructions that a robot has to follow in order to rearrange colourful bricks.

Code	Action
1	Pick-up Brick
0	Put-down Brick
Letter A to H	Move to section

The robot is about to rearrange the bricks stacked on the left into the structure on the right. The robot can move to the selected section. Each section is named with a letter. The section used in the command is referred to by the LEFTMOST side of each brick. The robot can carry only ONE brick at a time.

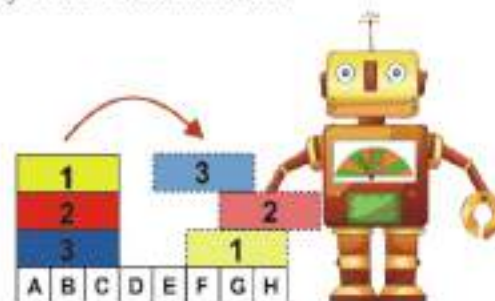

Question/Challenge:

What instructions does the robot have to receive to rearrange the bricks as shown in the picture?

- A) A1G0A1H1A1F0
- C) A1F0A1G0A1H0

- B) A1F0A1G0A1E0
- D) A10FA10GA10E

T20. Hotel Binary

Milo is working at the hotel. The task for today is to hang the new room numbers on each door. Starting next to room number 50 the rules are:

- if the new room number is less than the room number next to you, go left;
- if the new room number is greater than the room number next to you, go right;
- if the room next to you is not numbered, hang the new number there.

Some rooms are already numbered, as you can see.

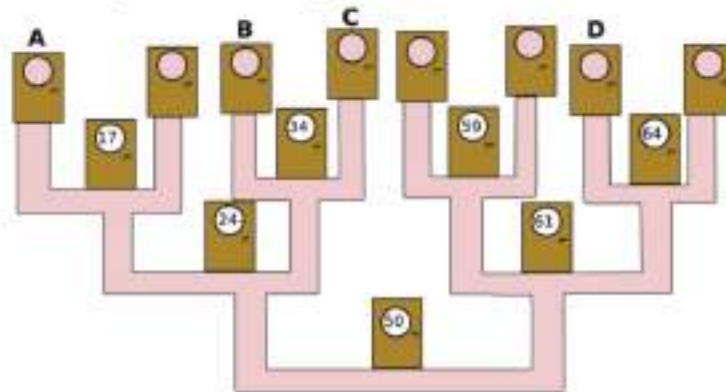

Question/Challenge:

Milo needs to hang the number 29. Following these rules, on which door should Milo hang the room number ?

A) A

B) B

C) C

D) D

Tasks T21 – T30 carry 5 points each

T21. Dinner Time

Cindy, Dennis, Eric, Frank and Gloria met in a restaurant. We know a few facts about their orders:

- Each item in the menu has been ordered at least once;
- Every person has ordered a soup, a main dish, and a drink;
- Eric, who has ordered the same soup as Frank, has chosen pasta as main dish;
- Two persons, who ordered vegetable soup, selected chicken respectively beef as the main dish;
- Gloria ordered orange juice and salad;



- Coke has been ordered only by Cindy and Dennis.
- A person who ordered tomato soup also selected pizza and orange juice.
- Cindy ordered chicken as main dish.

Question/Challenge:

According to this information, what is ordered by Dennis?

- | | | | |
|----|----------------|---------|-------|
| A) | Vegetable soup | Chicken | Coke |
| B) | Vegetable soup | Beef | Coke |
| C) | Tomato soup | Pasta | Water |
| D) | Tomato soup | Pizza | Coke |

T22. Rows and columns

Below on the left you see a picture of a game board with 4 pieces placed on it. We draw a diagram of this board, on the right of the picture, in the following way:

- For each piece on the board, draw a circle.
- If two pieces are in the *same row* on the board or in the *same column* on the board, then draw a line between their circles in the diagram.
- (Do not draw any other lines in the diagram.)



Letters have been placed on the pieces and the circles so you can easily check that the diagram is correct.

We have drawn a diagram in this way for the board with six pieces which you see here:



Question/Challenge:

Which of the four diagrams below were drawn?

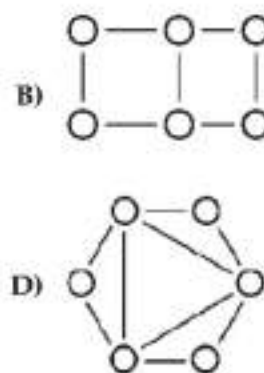
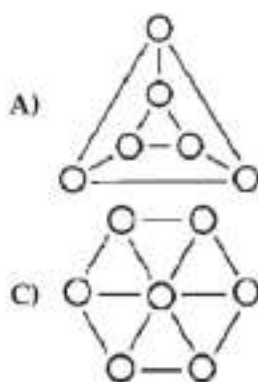

T23. Visit friends

Livia wants to visit all of her friends in the villages A, B, C, D, E by public transportation. She visits all of her friends in one journey, without visiting a village more than once, and she returns home at the end of her journey. The fare of each line is shown below. Notice that the maximum fare is three coins.

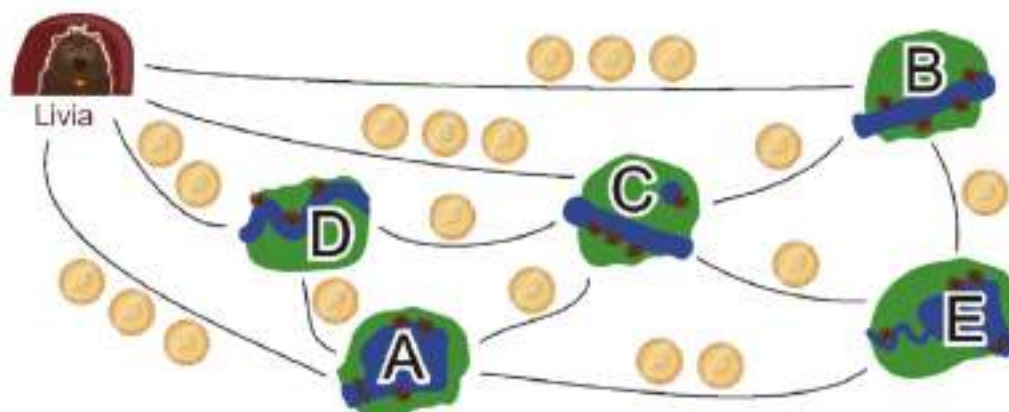

One possible order to visit her friends that costs 11 coins is:

Home → B → E → A → D → C → Home.

Question/Challenge:

Find a visiting order that costs Livia as few coins as possible. If there is more than one optimal solution, just find one.

- A) Home → B → E → C → A → D → Home
- B) Home → D → C → B → E → A → Home
- C) Home → C → D → A → E → B → Home
- D) Home → B → C → E → A → D → Home

T24. Elevator

A group of beavers are visiting the countryside and want to take the elevator up to the observation deck. But it's late and the elevator only goes up twice. The elevator has a load capacity of 30kg.



Question/Challenge:

What is the maximum number of beavers that fit into the two elevator trips ?



A) 9



B) 7

C) 8

D) 6

T25. Beaver Village Words II

Words used in a beaver village have the following characteristics;

- They use only three different characters: ,  and 
- A correct word reads the same backward as forward.

Examples of the correct words are shown below:

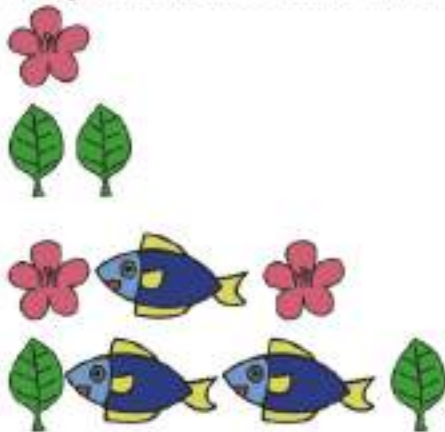

The length of a word is the number of characters used.

For example, the length of is 3.

Question/Challenge:

How many correct words can be made with length of 3?

- A) 6 B) 9 C) 18 D) 27

T26. Colouring In

The pattern below needs colouring in! This should be done using as few colours as possible; however, no two regions that share an edge are allowed to be the same colour.

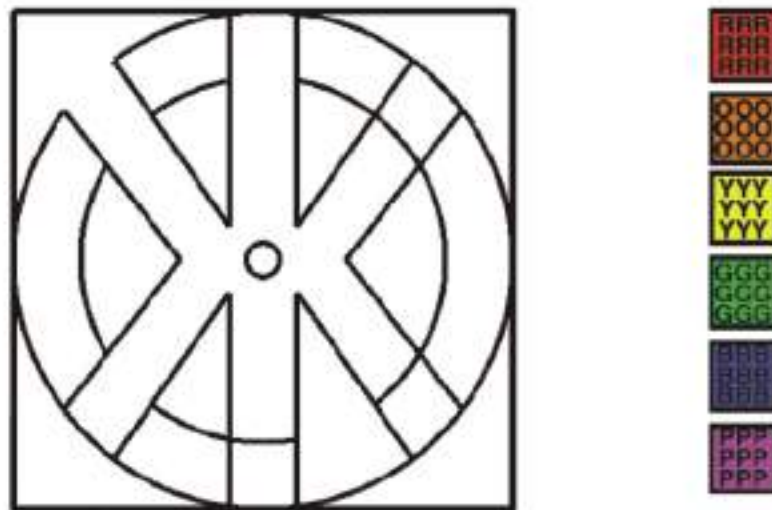

Question/Challenge:

What is the minimum number of colours required?

- A) 2 B) 3 C) 4 D) 5

T27. Balloon Words

Mark is going to Maria's birthday party. He can't see colours clearly, so for him yellow (C) looks the same as green (A), and blue (D) looks the same as red (B). Maria decorated the room with different rows of coloured balloons.

Question/Challenge:

Which two rows of balloons look the same to Mark?



A) 2 and 3

B) 1 and 4

C) 2 and 4

D) 1 and 3

T28. Beaver land

Beavers surround their village with a rope around the trees on the outside of the village. They then cut down the trees that are not needed to support the rope:



First they map the trees on a grid of squares like the one shown below. Then they select the smallest number of trees needed to support the rope. To make this easier the beavers assume that all trees have the same diameter (thickness) and are in the centre of the squares in the grid.

Question/Challenge:



How many trees can be cut down by the beavers in the plan below?
(All the trees in the village are marked as green circles.)

- A) 6
- C) 8

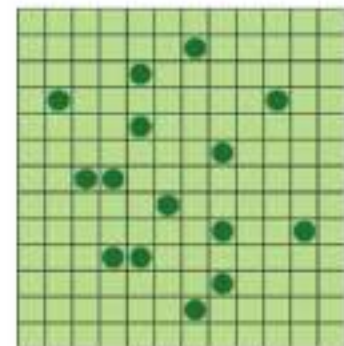
- B) 7
- D) 9



T29. Three friends

Bob , Alice  and Jenny  play alone in the locations represented by their vehicles. They want to set up a meeting place at an intersection to play together. Assume that they measure the distance by the total number of squares horizontally and vertically from their current positions to the meeting place.

Example: Distance from Alice  to meeting point  is 6.

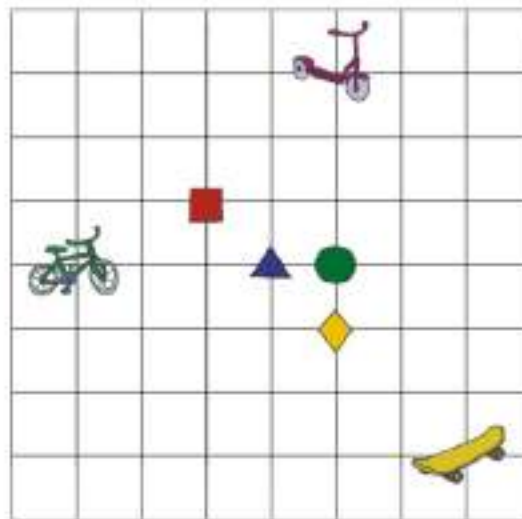

Question/Challenge:

Which meeting point should they choose, so all friends travel the shortest distance from their current positions?



T30. Echo and Response

Aron and Nora always disagree, but in a particular way. When one of them says a sentence composed of "Yes" and "No", the other will repeat that sentence followed by the sentence with every word reversed: that is, all "Yes"es become "No"s and all "No"s become "Yes"es. Here is a sample disagreement, where the **bolded** words are the opposite of the words they heard:

- Aron says: "No"
- Nora says: "No **Yes**"
- Aron says: "No Yes **Yes No**"
- Nora says: "No Yes Yes No **Yes No No Yes**"

In the last sentence said by Nora, the first word she said is "No" and the second word she said is "Yes".

Question/Challenge:

If this disagreement continues long enough, what are the 25th and 26th words spoken in each sentence?

A) Yes Yes

B) Yes No

C) No Yes

D) No No

